

INCH- POUND

MIL-I-17563C
18 September 1992
SUPERSEDING
MIL-I-17563B
4 April 1985
(See 6.6 and 6.9)

MILITARY SPECIFICATION

IMPREGNANTS FOR CAST OR POWDER METAL COMPONENTS

This specification is approved for use by all Departments and Agencies of the Department of Defense.

1. SCOPE

1.1 Scope. This specification covers the requirements for impregnants suitable for use in sealing the voids found in cast or powder metal components which cause leaking of contained fluids. This specification covers the impregnants in bulk form only and not after they have been used to impregnate the metallic component.

1.2 Classification. The impregnants shall be of the following classes (see 6.7):

- Class 1 - Suitable for service temperatures up to 300 degrees Fahrenheit (°F) (149 degrees Celsius (°C)).
- Class 1a - Suitable for use on mortar shell castings up to 300°F (149°C).
- Class 2 - Suitable for service temperatures up to 500°F (260°C).
- Class 3 - Suitable for use where air pollution requirements apply and compatible with acrylic-nitrocellulose lacquer paint system up to 300°F (149°C).

NOTE: Classes 1, 1a, and 2 may or may not contain volatile photochemically reactive solvents and should not be used where air pollution requirements are enforced.

Beneficial comments (recommendations, additions, deletions) and any pertinent data which may be of use in improving this document should be addressed to: Commander, ATTN: SEA 05Q42, Naval Sea Systems Command, 2531 National Center Building 3, Washington, DC 20362-5160 by using the Standardization Document Improvement Proposal (DD Form 1426) appearing at the end of this document or by letter.

AMSC N/A

FSC 6850

DISTRIBUTION STATEMENT A. Approved for public release; distribution is unlimited.

2. APPLICABLE DOCUMENTS

2.1 Government documents.

2.1.1 Specifications, standards, and handbooks. The following specifications, standards, and handbooks form a part of this document to the extent specified herein. Unless otherwise specified, the issues of these documents are those listed in the issue of the Department of Defense Index of Specifications and Standards (DODISS) and supplement thereto, cited in the solicitation (see 6.2).

SPECIFICATIONS

FEDERAL

- O-S-809 - Sulfuric Acid, Technical.
- P-C-111 - Carbon Removing Compound.
- P-D-680 - Dry Cleaning and Degreasing Solvent.
- TT-S-735 - Standard Test Fluids; Hydrocarbon.
- PPP-C-96 - Cans, Metal, 28 Gage and Lighter.
- PPP-P-704 - Pails, Metal: (Shipping, Steel, 1 Through 12 Gallons).

MILITARY

- MIL-E-463 - Ethyl Alcohol (for Ordinance Use).
- MIL-T-5624 - Turbine Fuel, Aviation, Grades JP-4, JP-5 And JP-5/JP8ST.
- MIL-L-7808 - Lubricating Oil, Aircraft Turbine Engine, Synthetic Base, NATO Code Number O-148.
- MIL-P-7962 - Primer Coating, Cellulose-Nitrate Modified Alkyd Type, Corrosion-Inhibiting, Fast-Drying (For Spray Application Over Pretreatment Coating).
- MIL-C-8514 - Coating Compound Metal Pretreatment, Resin-Acid.
- MIL-E-9500 - Ethylene Glycol, Technical.
- MIL-F-17111 - Fluid, Power Transmission.
- MIL-H-17672 - Hydraulic Fluid, Petroleum, Inhibited.
- MIL-F-18264 - Finishes: Organic, Weapons System, Application and Control Of.
- MIL-L-19537 - Lacquer: Acrylic-Nitrocellulose Gloss (For Aircraft Use).
- MIL-G-23827 - Grease, Aircraft and Instrument, Gear and Actuator Screw, NATO Code Number G-354, Metric.

STANDARDS

FEDERAL

- FED-STD-141 - Paint, Varnish, Lacquer, and Related Materials; Methods of Inspection, Sampling and Testing.
- FED-STD-313 - Material Safety Data, Transportation Data and Disposal Data for Hazardous Materials Furnished to Government Activities.

MIL-I-17563C

MILITARY

- MIL-STD-129 - Marking for Shipment and Storage.
- MIL-STD-276 - Impregnation of Porous Nonferrous Metal Castings.
- MIL-STD-286 - Propellants, Solid; Sampling, Examination and Testing.

(Unless otherwise indicated, copies of federal and military specifications, standards, and handbooks are available from the Standardization Documents Order Desk, Bldg. 4D, 700 Robbins Avenue, Philadelphia, PA 19111-5094.)

2.1.2 Other Government publication. The following other Government publication forms a part of this specification to the extent specified herein. Unless otherwise specified, the issues are those cited in the solicitation.

DEPARTMENT OF TRANSPORTATION (DOT)
Code of Federal Regulations, Title 49

(Application for copies should be addressed to the Superintendent of Documents, U.S. Government Printing Office, Washington, DC 20402.)

2.2 Non-Government publications. The following documents form a part of this document to the extent specified herein. Unless otherwise specified, the issues of the documents which are DOD adopted are those listed in the issue of the DODISS cited in the solicitation. Unless otherwise specified, the issue of documents not listed in the DODISS are the issues of the documents cited in the solicitation (see 6.2).

AMERICAN SOCIETY FOR TESTING AND MATERIALS (ASTM)
D 910 - Standard Specification for Aviation Gasolines.

(Application for copies should be addressed to the American Society for Testing and Materials, 1916 Race Street, Philadelphia, PA 19103.)

NATIONAL MOTOR FREIGHT TRAFFIC ASSOCIATION, INC., AGENT
National Motor Freight Classification

(Application for copies should be addressed to the National Motor Freight Traffic Association, Inc., ATA TRAFFIC Dept., 2200 Mill Road, Alexandria, VA 22314.)

UNIFORM CLASSIFICATION COMMITTEE AGENT
Uniform Freight Classification Ratings, Rules and Regulations

(Application for copies should be addressed to the Uniform Classification Committee Agent, Tariff Publication Officer, Room 1106, 222 South Riverside Plaza, Chicago, IL 60606.)

(Non-Government standards and other publications are normally available from the organizations that prepare or distribute the documents. These documents also may be available in or through libraries or other informational services.)

2.3 Order of precedence. In the event of a conflict between the text of this document and the references cited herein, (except for related specification sheets), the text of this document takes precedence. Nothing in this document, however, supercedes applicable laws and regulations unless a specific exemption has been obtained.

3. REQUIREMENTS

3.1 Qualification. The impregnants furnished under this specification shall be products which are authorized by the qualifying activity for listing on the applicable qualified products list at the time of award of contract (see 6.4 and 4.3).

3.2 Material. Material meeting the requirements of this specification shall be nonmetallic resins capable of being cured to a hard, dense structure which when cured shall produce a solid seal throughout a casting containing 15 percent porosity.

3.3 Volatility. The impregnant shall not contain inert liquids, nor react to produce gaseous or liquid by-products, either alone or in contact with materials present. The volatile content of class 3 sealant shall consist of nonphotochemically reactive solvents. A nonphotochemically reactive solvent is any solvent with an aggregate of not more than 20 percent of its total volume composed of the chemical compounds classified below or which does not exceed any of the following individual composition limitations, referred to the total volume of solvent:

- (a) A combination of hydrocarbons, alcohols, aldehydes, esters, ethers, or ketones having an olefinic or cycloolefinic type of unsaturation: 5 percent.
- (b) A combination of aromatic compounds with eight or more carbon atoms to the molecule except ethylbenzene: 8 percent.
- (c) A combination of ethylbenzene, ketones having branched hydrocarbon structures, trichloroethylene, or toluene: 20 percent.

3.4 Weight loss. This material shall not exhibit a weight loss exceeding 3 percent nor a volume loss exceeding 10 percent after curing.

3.5 Recovered materials. Unless otherwise specified herein, all material covered by this specification shall be new and may be produced from recovered materials to the maximum extent practicable without jeopardizing the intended use. The term "recovered materials" means materials which are recovered from waste and reprocessed to become a source of raw materials, as opposed to virgin raw materials.

3.6 Pot life. When tested as specified in 4.3.1.1; the activated impregnant shall have a pot life of not less than 1 month at $75 \pm 5^{\circ}\text{F}$ ($24 \pm 2.8^{\circ}\text{C}$) except for anaerobic ion cured impregnants which shall have a pot life of not less than 1 month at $45 \pm 5^{\circ}\text{F}$ ($8 \pm 2.8^{\circ}\text{C}$).

3.7 Storage life. Materials in unopened containers shall be usable and meet the manufacturer's original specification at the end of one year.

3.8 Curing. The impregnant shall cure to a hard firm mass when in contact with aluminum, copper, iron, magnesium, and zinc alloys (see 4.5.4.1). The cured material shall be free of obvious surface defects, holes, pits, and fissures. The sample with copper shall not show a greenish color.

3.9 Leakage. Impregnated test specimens shall show no leakage when impregnated as specified in 4.5.5.2 and tested as specified in 4.5.5.5. Leakage is indicated by a continuous flow of bubbles from within the casting.

3.10 Compatibility. The cured impregnant shall not be attacked by the chemicals listed in table III for the applicable class.

3.11 Effect on paint (class 3 only). The cured sealant shall not cause the paint system to chip, peel, or show loss of adhesion (see 4.6).

3.12 Reactivity (class 1a only). The reactivity of the class 1a impregnant with either TNT or Composition B explosive shall not exceed 2.0 ml of gas (see 4.7).

3.13 Filterable solids. The impregnant shall contain no filterable solids (see 4.5.2).

3.14 Toxic products and formulations. The material shall have no adverse effect on the health of personnel when used for its intended purpose. Conformance shall be determined by a health hazard risk assessment (HHRA) in accordance with 4.8. Products meeting this requirement will be issued a letter of approval by the Naval Sea Systems Command. Letters of approval shall apply solely to those products specifically evaluated for toxicity. Formulation changes in the product shall require a re-evaluation of the product for toxicity and a new letter of approval. Approval letters will be in effect for a maximum of three years, after which, re-issue may be requested. Manufacturers shall provide a copy of the approval letter applicable to offered products to the contracting activity before the product will be accepted (see 6.2). Questions pertaining to health hazards shall be referred by the Contracting Activity to Chief, Bureau of Medicine and Surgery, Department of the Navy, who will act as an advisor to the contracting Agency.

3.14.1 Hazard warning labels. A hazard warning label must be provided by the contractor in accordance with the requirements of the OSHA Hazard Communication Standard, 29 CFR 1910.1200. Specific information on implementation is included in MIL-STD-129.

3.15 Material safety data sheet (MSDS). The contracting activity shall be provided a material safety data sheet at contract award. The MSDS shall be provided in accordance with the requirements of FED-STD-313. The MSDS shall be included with each shipment of the material covered by this specification (see 6.6).

4. QUALITY ASSURANCE PROVISIONS

4.1 Responsibility for inspection. Unless otherwise specified in the contract or purchase order, the contractor is responsible for the performance of all inspection requirements (examinations and tests) as specified herein. Except as otherwise specified in the contract or purchase order, the contractor may use his own or any other facilities suitable for the performance of the inspection requirements specified herein, unless disapproved by the Government. The Government reserves the right to perform any of the inspections set forth in the specification where such inspections are deemed necessary to ensure supplies and services conform to the prescribed requirements.

4.1.1 Responsibility for compliance. All items shall meet all requirements of sections 3 and 5. The inspection set forth in this specification shall become a part of the contractor's overall inspection system or quality program. The absence of any inspection requirements in the specification shall not relieve the contractor of the responsibility of ensuring that all products or supplies submitted to the Government for acceptance comply with all requirements of the contract. Sampling inspection, as part of manufacturing operations, is an acceptable practice to ascertain conformance to requirements, however, this does not authorize submission of known defective material, either indicated or actual, nor does it commit the Government to accept defective material.

4.2 Classification of inspections. The inspection requirements specified herein are classified as follows:

- (a) Qualification inspection (see 4.3).
- (b) Quality conformance inspection (see 4.4).

4.3 Qualification inspection. Qualification inspection shall be conducted at a laboratory satisfactory to the Naval Sea Systems Command. Qualification inspection shall consist of the examinations of 4.3.1, 4.4 and the tests of 4.5, 4.6 and 4.7 including subparagraphs.

4.3.1 Material stability. The impregnating material shall meet the requirements of 3.6 and 3.7 when evaluated in accordance with 4.3.1.1 and 4.3.1.2.

4.3.1.1 Pot life test. Thermocuring materials shall be maintained for one month at $75 \pm 5^{\circ}\text{F}$ ($24 \pm 2.8^{\circ}\text{C}$). Anaerobic ion cured material shall be maintained, while under aeration, for one month at $45 \pm 5^{\circ}\text{F}$ ($8 \pm 2.8^{\circ}\text{C}$). At the end of the month an examination for evidence of thickening, curdling, and other objectionable property changes which prevent its use for the impregnation processes shall be made and the impregnant shall be tested to show compliance with 3.8.

4.3.1.2 Storage life test. Materials in unopened containers shall be examined at the end of one year and shall meet the requirements of 3.8 and 3.9 without any altering of the sample.

4.4 Quality conformance inspection. Quality conformance inspection shall consist of the tests specified in 4.5 through 4.5.5.5.

4.4.1 Sampling for quality conformance inspection. Quality conformance sampling shall be as follows:

4.4.1.1 Inspection lot. A sampling lot shall consist of all impregnant produced in a single production run and offered for delivery at one time.

4.4.1.2 Sample for conformance to preparation for delivery. Samples of filled containers shall be randomly selected from each lot in accordance with table I to verify compliance with this specification in regard to fill, closure and marking. Each type container shall be sampled separately when shipment consists of mixed lots.

TABLE I. Sampling for preparation for delivery.

Lot size (Containers)	Number of samples
1 to 4	All
5 to 50	5
51 to 90	7
91 to 150	11
151 to 280	13
281 to 500	16
501 to 1200	19
1201 to 3200	23
3201 to 10000	29
10001 to 35000	35
35001 and over	40

4.4.1.3 Examination of filled containers. Each sample (filled container), selected as specified in 4.4.1.2, shall be examined for defects of construction of the container and closure, for evidence of leakage, and for markings as specified in MIL-STD-129. Filled containers shall also be weighed. The volume shall be established by the weight per gallon of the impregnant (see 4.5.3). Any container in the sample having one or more defects, or underfill, as determined by weight, shall result in the rejection of the lot. Rejected lots may be resubmitted for inspection provided the contractor has removed or repaired all nonconforming containers in the entire lot.

4.4.1.4 Inspection of curing. A sample from one container of the resin cured per manufacturers instruction shall be examined to determine that it meets the requirements specified in 3.8.

4.5 Test methods.

4.5.1 Test sample. The test sample shall consist of 1 gallon (3.8 liters) of the impregnant plus the necessary activator and curing instructions supplied by the manufacturer.

4.5.2 Test for filterable solids. The test sample shall be drawn through a Watman No. 5 filter paper or equivalent. The filter paper shall be examined visually during and after the filtration for evidence of loading by solids.

4.5.3 Weight per gallon. The weight per gallon of the resin shall be determined according to FED-STD-141, method 4184.1.

4.5.4 Cure tests. The impregnant shall meet the requirement of 3.8 when in contact with each of the following metals individually: aluminum, copper, iron, magnesium and zinc. The metals shall be in the form of fine dry chips. The chips shall be just covered with activated impregnant for not less than 24 hours and then cured according to the manufacturers instructions.

4.5.4.2 Shrinkage test. A sample of the material shall have its volume determined and then be cured under conditions recommended for the impregnant by its manufacturer. After cooling to room temperature, the volume of the cured material shall be measured. The change in volume, if any, shall not exceed the requirement of 3.4.

4.5.4.3 Weight loss. Not less than 5 cubic centimeters (cm^2) cm^3 of the activated impregnant shall be carefully weighed on an analytical balance, cured in accordance with the manufacturers instructions, and reweighed for compliance with 3.4.

4.5.5 Sealing capability tests.

4.5.5.1 Test specimens.

4.5.5.1.1 Configuration. Test specimens shall consist of a sintered metal powder cylinder, 1 inch (25.4mm) long with a nominal 3/4 inch (19.0mm) inside diameter and a 1.00 inch (25mm) outside diameter, as shown on figure 1. Specimens shall not have surfaces altered by operations such as burnishing, coining or sizing. The interconnected voids by volume (porosity) shall be 15 to 25 percent as determined by the method specified in ASTM B 328. The alloy composition of the test specimens shall conform to one of the three types as specified in table II.

TABLE II. Powder metal test specimen chemical composition.

Element	Composition percent		
	Type I	Type II	Type III
Copper	82.0 - 90.0	---	---
Iron	1.0 (max)	95.0 (min)	---
Tin	9.5 - 10.5	---	---
Lead, maximum	4.0	---	---
Zinc, maximum	1.0	---	---
Aluminum, minimum	----	---	99.0
Carbon, maximum ¹	1.75	---	---
Total other elements by diff., maximum percent	0.5	4.0	1.0
Combined carbon ² (on basis of iron only)	----	0.60 - 1.00	---

¹ Commonly graphite. A maximum of 1-1/2 percent of another type of solid lubricant may be substituted when authorized.

² The combined carbon may be a metallographic estimate of the carbon in the iron.

4.5.5.1.2 Specimen preparation. Specimens shall be placed in the pressure test apparatus of 4.5.5.3 and subjected to 20 lb/in² for a minimum of 5 minutes or until bubbling occurs to test for leakage prior to impregnating. Specimens that are to be subsequently impregnated shall be dried by placing in an oven at 250°F for 1 hour.

4.5.5.2 Impregnation. Test specimens for the tests of 4.5.5.4 shall be impregnated in accordance with MIL-STD-276.

4.5.5.3 Test method. The pressure test apparatus shall be made as shown on figure 2. Specimens shall be placed in the test apparatus, immersed in water and subjected to the air pressure specified in each individual test for a minimum of 3 minutes or until leak occurs. The specimen shall leak or not leak as stated in the individual test.

4.5.5.4 Pressure penetration test. One impregnated test specimen of each type shall be machined to remove a minimum of 1/16th inch of material from the outer diameter, then etched with 6N nitric acid to remove 0.005 inch of material from the outer surface. The test specimens so prepared shall be subjected to 50 lb/in² aerostatic pressure with no leakage as specified in 3.7.

4.5.5.5 Pressure leakage test. After impregnation as specified in 4.5.5.2 two test specimens shall be tested for leakage at 50 lb/in². No leakage shall be permitted.

4.5.5.6 Environmental pressure conditioning test. Two impregnated test specimens of each type as shown in table III shall be conditioned in each of the media as listed in table III and shall show no leakage when tested at 50 lb/in².

MIL-I-17563C

The conditioning time and temperature shall be as specified in table III. Only specimens showing no leakage when tested to 4.5.5.5 shall be used. All of the tests indicated for each impregnant class shall be performed.

TABLE III. Conditioning tests.

Impregnant Class	Specimen Type	Material	Media Specification	Time	Temperature
1, 1a, 2, 3	All	Water	-----	14 days	212°F(100°C) (Boiling)
	All	Oil	MIL-H-17672	14 days	210 ± 5°F (99 ± 2.8°C)
	All	Hydrocarbon fluid	TT-S-735	14 days	73.4 ± 3.6°F (23 ± 2°C)
	All	Carbon Removal	P-C-111	30 minutes	73.4 ± 3.6°F (23 ± 2°C)
	All	Lubricating oil	MIL-L-7808	48 hours	255 ± 5°F (121 ± 2.8°C)(1)
	All	Turbine fuel	MIL-T-5624	48 hours	73.4 ± 3.6°F (23 ± 2°C)
	All	Ethylene glycol	MIL-E-9500	14 days	C1 1=300±5°F (149±2.8°C)(2) C1 2=397±5°F (197±2.8°C)(2)
	1, 1a, 2, 3	All	Hydraulic fluid	MIL-F-17111	14 days
All		Fuel	ASTM D 910	48 hours	73.4±3.6°F (23±2°C)
All		Diester grease	MIL-G-23827	48 hours	73.4±3.6°F (23±2°C)
All		18 percent Sulfuric acid	O-S-809	2 hours	73.4±3.6°F (23±2°C)
All		Stoddard solvent	P-D-680	48 hours	73.4±3.6°F (23±2°C)
All		Ethyl alcohol	MIL-E-463	48 hours	73.4±3.6°F (23±2°C)
1, 1a, 2, 3		All	Thermal resistance	-----	14 days
	All	Thermal resistance	-----	14 days	500±5°F (260±2.8°C)(2)

NOTES:

- (1) Specimens shall be cleaned in a suitable degreaser after exposure.
- (2) Specimens shall be cleaned in a suitable degreaser for not less than 30 minutes prior to exposure to the stated conditions.

4.6 Effect on paint systems (class 3 only). Two test specimens of each type impregnated with class 3 impregnant shall be heated at 300°F (149°C) for 4 hours, air cooled to room temperature, then placed in a refrigerated area held at $-65 \pm 5^\circ\text{F}$ ($-54 \pm 2.8^\circ\text{C}$) for not less than 1 hour. Immediately upon removal from refrigeration, the specimens shall be subjected to the internal aerostatic pressure. The test specimens shall be dried and reimpregnated. The following lacquer system shall then be applied to the test specimens in accordance with MIL-F-18264: One coat each of wash primer in accordance with MIL-C-8514, lacquer primer in accordance with MIL-P-7962, and acrylicnitrocellulose lacquer in accordance with MIL-L-19537. The system shall be allowed to dry for 48 hours and then tested in accordance with method 6304 of FED-STD-141 to meet the requirement as specified in 3.11.

4.7 Reactivity.

4.7.1 Test method. The test for reactivity of the class 6 impregnant with explosives shall be conducted in accordance with method 403.1.2 of MIL-STD-286. The tests shall be conducted at 212°F (100°C) in a constant temperature bath. Specimens having the following composition shall be tested:

- (a) 2.5 grams of aluminum chips impregnated with class 1a impregnant. (A type II specimen shall be impregnated and chips machined there from.)
- (b) 2.5 grams of TNT (see 6.2.1).
- (c) 2.5 grams of Composition B explosive (see 6.2.1).
- (d) 2.5 grams of aluminum chips impregnated with class 1a resin mixed with 2.5 grams of TNT.
- (e) 2.5 grams of aluminum chips impregnated with class 1a resin mixed with 2.5 grams of Composition B explosive.

4.7.2 Calculation. The unit capacity of the capillary and the volume of gas liberated during the test shall be calculated as specified in method 403.1.2 of MIL-STD-286. The reactivity of the impregnant with the explosives shall be calculated as follows:

Reactivity, in ml of gas liberated = $x - (y+z)$

x - ml of gas produced by the 1:1 mixture of 2.5 grams of explosive plus 2.5 grams of class 6 impregnated. Metal chips (type III only) as described in (d) and (e) above.

y - ml of gas produced by 2.5 grams of impregnated specimen alone.

z - ml of gas produced by 2.5 grams of explosive alone.

Reactivity shall meet the requirement of 3.12.

4.8 Toxicity. The manufacturer shall provide sufficient information to permit a toxicological evaluation of his product to the Navy Environmental Health Center (NEHC), accompanied with a request to perform a health hazard risk assessment (HHRA). As a minimum, the information shall include name, formula and approximate percentage by weight of each ingredient in the product; identification

of its pyrolysis products; and any other information as may be needed to permit an accurate appraisal of any toxicity problem associated with the handling, storage, application, use, removal, disposal, or combustion of the product. The request for HHRA shall also include a product material safety data sheet and a copy of the product label. The manufacturer shall provide any other information requested by NEHC to perform their evaluation. Proprietary data, which is clearly marked as such, will be held in the strictest confidence by NEHC. The request for a HHRA shall be addressed to the Commanding Officer, Navy Environmental Health Center, 2510 Walmer Avenue, Norfolk, Virginia 23513-2617, Attention: Mr. J.R. Crawl, CIH/NEHC-34. The manufacturer shall also send a copy of the letter which requests the HHRA to the Chief, Bureau of Medicine and Surgery (MED-03B4), Washington, DC 20372-5120. Upon receipt of the HHRA performed by NEHC, the manufacturer shall send a copy to the Naval Sea Systems Command, Code OSM, Washington, DC 20362-5160, with a request for approval.

4.9 Inspection of packaging. Sample packages and packs, and the inspection of the preservation-packaging, packing and marking for shipment, stowage, and storage shall be in accordance with the requirements of section 5 and the documents specified therein.

5. PACKAGING

(The packaging requirements specified herein apply only for direct Government acquisitions.)

5.1 Packaging. Packaging shall be level A or C, as specified (see 6.2).

5.1.1 General requirements. General requirements for packaging shall be as follows:

- (a) Aerobic thermal cure material. Unless otherwise specified (see 6.2), the impregnant shall be packaged in screw top or multiple friction top rectangular cans, steel pails, or metal drums, whether furnished in a liquid, jelly or powdered form. When components required to equal one unit of issue, producing the specific quantity of product, shall be packaged together as a kit in a unit container. The capacity and style of the containers shall be as specified by the contracting activity (see 6.2).
- (b) Anaerobic ion cure material. Unless otherwise specified (see 6.2), the impregnant shall be packaged in rectangular screw top low density polyethylene carbons.

5.1.2 Level A.

5.1.2.1 Liquid materials. Liquid materials shall be packaged in rectangular cans with a screw cap closure not exceeding 1-gallon capacity in accordance with type I of PPP-C-96; closed top style 5-gallon steel drum in accordance with type I, class 4, 5 and 6 of PPP-P-704 with screw cap closure; or in 17C or 5B metal drums, with closed top style and double seamed-in head in accordance with 17E of the Department of Transportation (DOT) Regulations, Title 49.

5.1.2.2 Powdered and jelly-type material. Powdered or jelly-type materials shall be packaged in round containers with a multiple friction top closure not exceeding 1-gallon capacity in accordance with type V, class 2 of PPP-C-96; 5-gallon round open top style containers with 16 lug closures, in accordance with type V, class 2 of PPP-C-96; or in 6- to 55-gallon open top style metal drums, with bolted ring seal closures and with side seams welded, in accordance with 37D of DOT Regulations, Title 49.

5.1.3 Level C. Preservation-packaging shall afford protection against deterioration and physical damage. The contractor's normal retail or wholesale preservation-packaging methods may be utilized when such meets the requirements.

5.2 Packing. Packing shall be level A, B or C, as specified (see 6.2).

5.2.1 Levels A and B containers. The cans shall be packed in accordance with the appendix of PPP-C-96. Drums will require no overpacking.

5.2.2 Level C. The impregnant shall be packed for shipment in a manner acceptable to the common carrier and which will ensure safe delivery at destination, in a satisfactory condition, at the lowest applicable rate. Containers, packing, or method of shipment shall comply with Uniform Freight or National Motor Freight Classification Rules or Regulations or other carrier rules, as applicable, to the mode of transportation.

5.3 Marking. In addition to any special marking required (see 6.2), unit containers and exterior shipping containers shall be marked in accordance with MIL-STD-129, and shall include the date of manufacture and special storage instructions, as necessary.

5.4 Special marking. The container shall be marked with recommended mixing procedures.

5.5 Material safety data sheet. A copy of the material safety data sheet (Form OSHA-20) shall be attached to the shipping document for each destination (see 3.15).

6. NOTES

(This section contains information of a general or explanatory nature that may be helpful, but is not mandatory.)

6.1 Intended use. The impregnating material covered by this specification is intended to seal porosities present in aluminum, copper, irons, (excluding steels) magnesium, and zinc alloy castings or powdered metal components. Impregnating materials are not to be used to effect acceptance of an unacceptable casting.

6.2 Acquisition requirements. Acquisition documents must specify the following:

- (a) Title, number, and date of this specification.
- (b) Class of impregnant required (see 1.2).
- (c) Issue of DODISS to be cited in the solicitation and if required, the specific issue of individual documents referenced (see 2.1.1 and 2.2).
- (d) Submittal of Naval Sea Systems Command approval letter regarding toxicity (see 3.14).
- (e) Levels of packaging and packing required (see 5.1 and 5.2).
- (f) Size and type of containers required (see 5.1.1).

6.2.1 TNT and Composition B explosive can be obtained from the following:

E. I. DuPont de Nemours Inc.
Wilmington, Delaware

Eastman Kodak Corp.
Rochester, New York

6.3 Consideration of data. The following Data Item Descriptions (DIDs) should be considered when this specification is applied on a contract. The applicable Data Item Descriptions (DIDs) should be reviewed in conjunction with the specific acquisition to ensure that only essential data are requested/provided and that DIDs are tailored to reflect the requirements of the specific acquisition. To ensure correct contractual application requirements, a Contract Data Requirements List (DD Form 1423) must be prepared to obtain the data, except where DOD FAR Supplemental 27.475-1 exempts the requirement for a DD Form 1423.

<u>Reference paragraph</u>	<u>DID number</u>	<u>DID title</u>	<u>Suggested tailoring</u>
4.1, 4.1.1, 4.5	DI-NDTI-80809	Test reports	-----

The above DIDs were cleared as of the date of this specification. The current issue of DOD 5010.12-L, Acquisition Management Systems Data Requirements Control List (AMS DL), must be researched to ensure that only current cleared DIDs are cited on the DD Form 1423.

6.4 Qualification. With respect to products requiring qualification, awards will be made only for products which are, at the time of award of contract, qualified for inclusion in Qualified Products List QPL No. 17563 whether or not such products have actually been so listed by that date. The attention of the contractors is called to these requirements, and manufacturers are urged to arrange to have the products that they propose to offer to the Federal Government tested for qualification in order that they may be eligible to be awarded contracts or purchase orders for the products covered by this specification. The activity responsible for the Qualified Products List is the Naval Sea Systems

MIL-I-17563C

Command, SEA 05Q22, 2531 National Center Building 3, Washington, DC 20362-5160 and information pertaining to qualification of products may be obtained from that activity. Application for qualification tests may be made in accordance with "Provisions Governing Qualification SD-6" (see 6.4.1).

6.4.1 Copies of "Provisioning Governing Qualification SD-6" may be obtained upon application to the Standardization Documents Order Desk, Bldg 4D, 700 Robbins Avenue, Philadelphia, PA 19111-5094.

6.5 Subcontracted material and parts. The preparation for delivery requirements of referenced documents listed in section 2 do not apply when material and parts are acquired by the contractor for incorporation into the equipment and lose their separate identity when the equipment is shipped.

6.6 Material safety data sheets. Contracting officers will identify those activities requiring copies of completed Material Safety Data Sheets prepared in accordance with FED-STD-313. The pertinent Government mailing addresses for submission of data are listed in FED-STD-313.

6.7 Supersession data. This specification includes the requirements of MIL-I-13857B, dated 17 February 1984 (see table IV) and MIL-I-6869D dated 14 January 1971.

TABLE IV. Supersession data.

MIL-I-17563C	MIL-I-17563B	MIL-I-6869D	MIL-I-13857
Class 1	Class 1	Class 1	-----
Class 2	Class 2	-----	-----
Class 3	Class 3	Class 2	-----
Class 1, 2, 3	Class 4	-----	-----
Class 1	-----	-----	Type I
Class 1a	-----	-----	Type II

6.8 Subject term (key word) listing.

Aerobic
 Anaerobic
 Castings
 Porosity
 Resins
 Sealing

6.9 Changes from previous issue. Asterisks are not used in this revision to identify changes with respect to the previous issue due to the extensiveness of the changes.

Custodians:

Army - EA
Navy - SH

Preparing activity:

Navy - SH
(Project 6850-1056)

Review activities:

Army - MR
DLA - GS

User activity:

Navy - AS, OS

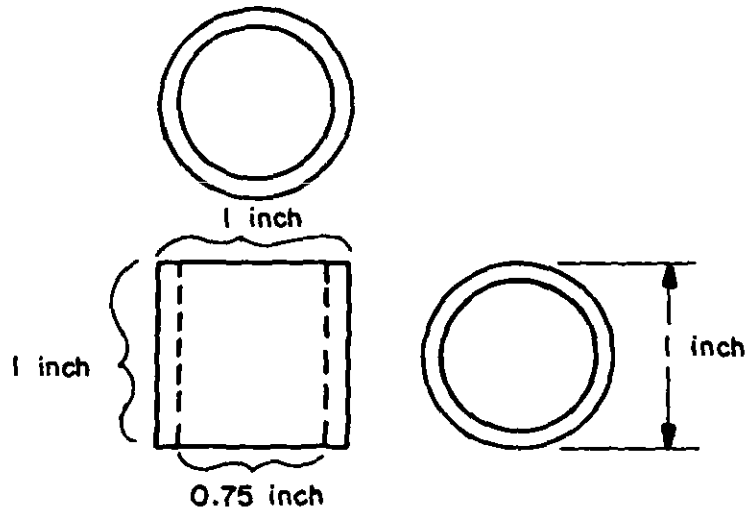

FIGURE 1. Test specimen dimensions (nominal).

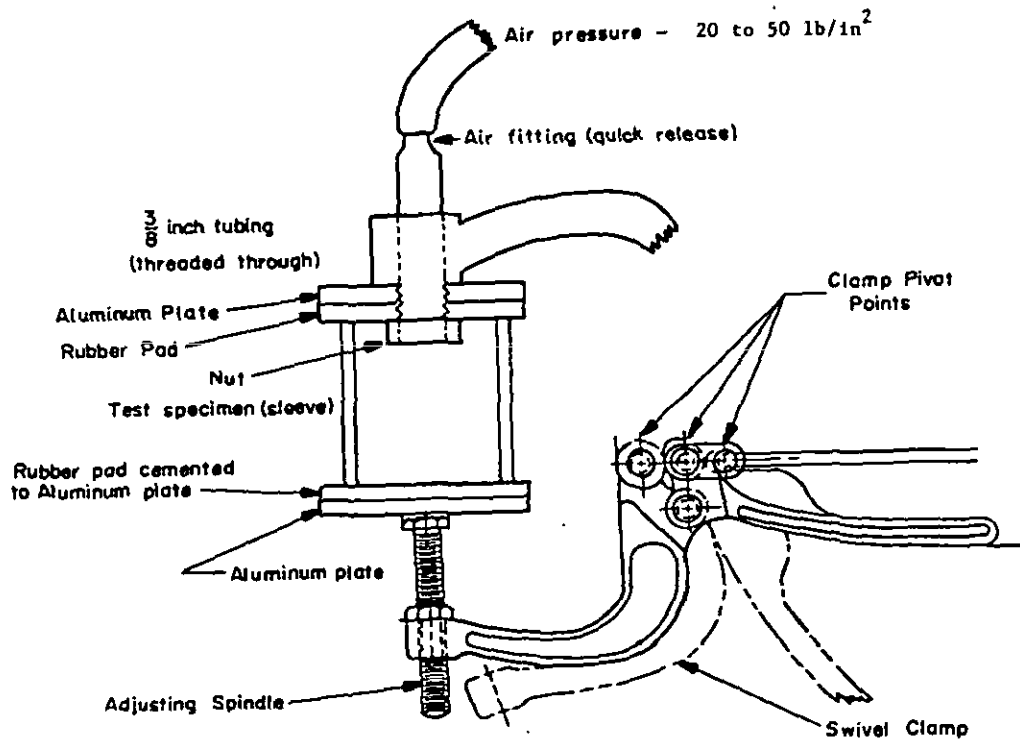

FIGURE 2. Test apparatus with test specimen adaptation of DE-STA-CO clamp 474.

STANDARDIZATION DOCUMENT IMPROVEMENT PROPOSAL

INSTRUCTIONS

1. The preparing activity must complete blocks 1, 2, 3, and 8. In block 1, both the document number and revision letter should be given.
2. The submitter of this form must complete blocks 4, 5, 6, and 7.
3. The preparing activity must provide a reply within 30 days from receipt of the form.

NOTE: This form may not be used to request copies of documents, nor to request waivers, or clarification of requirements on current contracts. Comments submitted on this form do not constitute or imply authorization to waive any portion of the referenced document(s) or to amend contractual requirements.

I RECOMMEND A CHANGE:	1. DOCUMENT NUMBER MIL-I-17563C	2. DOCUMENT DATE (YYMMDD) 1992 09 18
3. DOCUMENT TITLE Impregnants For Cast Or Powder Metal Components		
4. NATURE OF CHANGE (Identify paragraph number and include proposed rewrite, if possible. Attach extra sheets as needed.)		
5. REASON FOR RECOMMENDATION		
6. SUBMITTER		
a. NAME (Last, First, Middle Initial)	b. ORGANIZATION	
c. ADDRESS (Include Zip Code)	d. TELEPHONE (Include Area Code) (1) Commercial (2) AUTOVON (If applicable)	7. DATE SUBMITTED (YYMMDD)
8. PREPARING ACTIVITY		
a. NAME TECHNICAL POINT OF CONTACT (POC): MR. John Forney SEA 05M22	b. TELEPHONE (Include Area Code) (1) Commercial (703) 602-0143	(2) AUTOVON 8-332-0143
c. ADDRESS (Include Zip Code) Commander, SEA 05Q42 Naval Sea Systems Command 2531 National Center Building 3 Washington, DC 20362-5160	IF YOU DO NOT RECEIVE A REPLY WITHIN 45 DAYS, CONTACT: Defense Quality and Standardization Office 5203 Leesburg Pike, Suite 1403, Falls Church, VA 22041-3466 Telephone (703) 756-2340 AUTOVON 289-2340	